

04.16.2017

# BẢNG GIÁ

BREAKER & SWITCHGEAR SYSTEM



<http://circuit-breaker.seec.com.tw>



**No.1**  Taiwan

# ELECTRIC COMPANY in TAIWAN

Shihlin Electric Light Up Taipei 101,  
One Of World Tallest Buildings

POWER  
TO THE  
WORLD



Air Circuit Breaker



Molded Case  
Circuit Breaker



Miniature  
Circuit Breaker

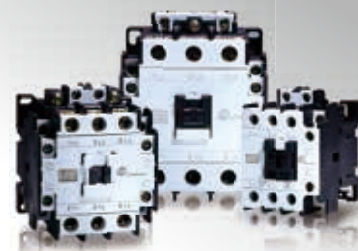

Magnetic  
Contactor / Starter



**KEMA  
KEUR**

Type		BMA160		BMA250		BMA400	
Frame Size		160AF		250AF		400AF	
Model		STA	LTA	STA	LTA	HTA	RTA
Pole		3P / 4P		3P / 4P		3P / 4P	
Frequency (Hz)		50 / 60		50 / 60		50 / 60	
Rated Current, In		40.50.60.63.70.75.80.100. 125.140.150.160A		175.200.225.250A		250.300.350.400A	
Breaking Capacity, Icu (AC)	690V	8 kA	8 kA	10 kA	10 kA	10 kA	15 kA
	415V	25 kA	36 kA	25 kA	36 kA	50 kA	70 kA
	380V	25 kA	36 kA	25 kA	36 kA	50 kA	70 kA
Ics (%Icu)		100		100		100	
Dimension W x H x D (mm)	3P	105 x 165 x 68		105 x 165 x 68		140 x 257 x 103	
	4P	140 x 165 x 68		140 x 165 x 68		185 x 257 x 103	
Weight (kg)	3P	1.5		1.5		5.7	
	4P	1.9		1.9		7.5	

Type		BMA630		BMA800	
Frame Size		630AF		800AF	
Model		HED	RED	HED	RED
Pole		3P / 4P		3P / 4P	
Frequency (Hz)		50 / 60		50 / 60	
Rated Current, In		630A		800A	
Breaking Capacity, Icu (AC)	690V	10 kA	15 kA	10 kA	15 kA
	415V	50 kA	70 kA	50 kA	70 kA
	380V	50 kA	70 kA	50 kA	70 kA
Ics (%Icu)		100		100	
Dimension W x H x D (mm)	3P	210 x 275 x 103		210 x 275 x 103	
	4P	280 x 257 x 103		280 x 257 x 103	
Weight (kg)	3P	11.5		12	
	4P	15.3		15.8	



**Giá bán đã bao gồm thuế VAT 10%**

**MCCB / ELCB**

**MCCB (Aptomat) 2P Tiêu chuẩn IEC60947-2**

Mã hàng	Dòng định mức (A)	kA	Đơn giá (VND)
BM 30-CN 2P	5.10.15.20.30A	1.5	397,000
BM 50-CN 2P	40.50A	2.5	510,000
BM 100-MN 2P	15.20.30.40.50A	10	704,000
	60.75.100A		740,000
BM 100-SN 2P	15.20.30.40.50.60.75.100A	15	788,000
BM 400-CN 2P	250.300.350.400A	25	3,728,000

**MCCB (Aptomat) 3P Tiêu chuẩn IEC60947-2 (Chỉnh dòng 0.8~1\*In)**

Mã hàng	Dòng định mức (A)	kA	Đơn giá (VND)
BM 250-SN 2P	125~250A(0.8~1*In Adj.)	30	1,491,000

**MCCB (Aptomat) 3P Tiêu chuẩn IEC60947-2**

Mã hàng	Dòng định mức (A)	kA	Đơn giá (VND)
BM 30-CN 3P	5.10.15.20.30A	1.5	551,000
BM 50-CN 3P	40.50A	2.5	567,000
BM 100-MN 3P	15.20.30.40.50A	7.5	706,000
	60.75.100A		830,000
BM 100-SN 3P	15.20.30.40.50A	15	725,000
	60.75.100A		872,000
BM 125-SN 3P	15.20.30.40.50A	22	1,075,000
	60.75.100.125A		
BM 100-HN 3P	15.20.30.40.50.60.75.100A	30	1,350,000
BM 100-H 3P	15.20.30.40.50.60.75.100A	50	2,800,000
BM 250-HB 3P	125.150.175.200.225.250A	50	4,050,000
BM 400-CN 3P	250.300.350.400A	25	4,337,000
BM 400-SN 3P		35	4,673,000
BM 400-HN 3P		50	4,950,000
BM 630-SN 3P		35	8,264,000
BM 630-HN 3P		50	11,500,000
BM 800-CN 3P		35	9,780,000
BM 800-SN 3P	700.800A	50	12,100,000
BM 1000-HS 3P	1000A		22,900,000
BM 1200-HS 3P	1200A	100	27,400,000
BM 1600-HS 3P	1600A		37,000,000

**MCCB (Aptomat) 3P Chỉnh dòng 0.8~1\*In**

Mã hàng	Dòng định mức (A)	kA	Đơn giá (VND)
BM 100-HBN 3P	40.50.63.80.100A	36	2,310,000
BM 250-CN 3P	125.150.175.200A 225.250A	22	1,785,000
BM 250-SN 3P		30	1,901,000
BM 250-HN 3P		36	2,210,000

**EMCCB (Aptomat) 3P IEC60947-2 Chỉnh dòng điện từ 0.4~1\*In**

Mã hàng	Dòng định mức (A)	kA	Đơn giá (VND)
BM 400-HE 3P	400A	50	7,280,000
BM 630-RE 3P	630A	70	16,500,000
BM 800-HE 3P	800A		17,800,000
BM 1000-HE 3P	1000A	85	38,500,000
BM 1250-HE 3P	1250A		40,700,000

**MCCB (Aptomat) 4P Tiêu chuẩn IEC60947-2**

Mã hàng	Dòng định mức (A)	kA	Đơn giá (VND)
BM 100-SN 4P	15.20.30.40.50A	15	1,034,000
BM 100-HN 4P	60.75.100A	30	1,397,000
BM 250-SN 4P	125~250A (0.8~1*In Adj.)	30	2,365,000
BM 250-HN 4P		36	3,080,000
BM 400-SN 4P	250.300.350.400A	35	5,775,000
BM 400-HN 4P		50	6,820,000
BM 630-SN 4P	500.630A	35	11,880,000
BM 630-HN 4P		50	12,430,000
BM 800-SN 4P	700.800A	50	14,300,000
BM 800-HN 4P		70	18,590,000

**Phụ kiện MCCB – Bộ khởi động On/Off MCCB**

Mã hàng	Đơn giá (VND)
MT-100N	7,000,000
MT-125N	7,300,000
MT-250N	8,000,000
MT-250E	8,200,000
MT-400N	11,000,000
MT-800N	12,300,000

**Phụ kiện MCCB**

Mã hàng	Đơn giá (VND)		
	SHT	UVT	AUX
BM-50CN/100MN.SN	616,000	1,230,000	300,000
BM-100HN/125SN	660,000	1,444,000	380,000
BM-250CN.SN	869,000	1,630,000	460,000
BM-400CN.SN.HN	970,000	1,780,000	720,000
BM-630/800CN.SN	1,390,000	2,150,000	880,000
BM-1000~1600 HS	2,288,000	4,300,000	1,700,000

**CB Chống giật Tiêu chuẩn IEC60947-2 Chỉnh dòng 30 - 100 – 500mA 0.1s**

Mã hàng	Dòng định mức (A)	kA	Đơn giá (VND)
BL 100-SN 3P	15.20.30.40.50A	15	1,680,000
	60.75.100A		1,780,000
BL 160-SN 3P	125.140.160A	30	3,480,000
BL 250-SN 3P	175.200.225.250A		3,500,000
BL 400-SN 3P	250.300.350.400A	35	7,400,000
BL 630-HN 3P	500.630A	50	12,000,000
BL 100-SN 4P	15~100A	15	2,900,000
BL 100-HN 4P		30	3,300,000
BL 160-SN 4P	125.140.160A	30	5,570,000
BL 250-SN 4P	175.200.225.250A		5,700,000
BL 400-SN 4P	250.300.350.400A	35	11,600,000
BL 630-HN 4P	500.630A	50	16,800,000

**MCB (CB Tép) Tiêu chuẩn CNS14816-2 Màu đen**

Mã hàng	Dòng định mức (A)	kA	Đơn giá (VND)
BP 1P	15.20.30.40.50A	5	104,000
	60.75.100A		191,000
BP 2P	15.20.30.40.50A	5	216,000
	60.75.100A		373,000
BP 3P	15.20.30.40.50A	5	365,000
	60.75.100A		657,000
BPH 1P	15.20.30.40.50A	10	159,000
BPH 2P	15.20.30.40.50A		273,000
	BPH 3P	60.75.100A	477,000
BPH 3P		15.20.30.40.50A	10
	60.75.100A	958,000	



**Direct motor starting (A)**

kW	HP																																					
	0.05	0.1	0.15	0.2	0.3	0.37	0.55	0.75	1.1	1.5	2.2	3	4	5.5	7.5	9	11	15	18.5	22	30	37	45	55	65	75	90	110	132	150	160	200	220	270	300	315	420	
Motor rating	A																																					
	Motor full load current																																					
220V	A																																					
	Magnetic switch																																					
3φ	A																																					
	Thermal overload relay																																					
50 / 60 Hz	A																																					
	Fused (VDE0660 gT, delay type)																																					
30-SN	A																																					
	Circuit breaker																																					
30-SN	A																																					
	Rated current																																					
30-SN	A																																					
	Motor full load current																																					
380V	A																																					
	Magnetic switch																																					
1φ	A																																					
	Thermal overload relay																																					
50 / 60 Hz	A																																					
	Fused (VDE0660 gT, delay type)																																					
30-SN	A																																					
	Circuit breaker																																					
30-SN	A																																					
	Rated current																																					
30-SN	A																																					
	Motor full load current																																					
220V	A																																					
	Magnetic switch																																					
1φ	A																																					
	Thermal overload relay																																					
50 / 60 Hz	A																																					
	Fused (VDE0660 gT, delay type)																																					
30-SN	A																																					
	Circuit breaker																																					
30-SN	A																																					
	Rated current																																					
30-SN	A																																					
	Motor full load current																																					

\*\*\* means VDE0660 gF quick acting type

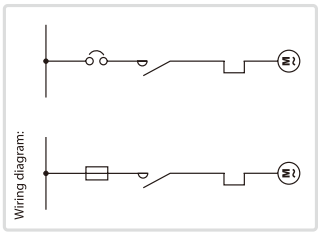

**Motor A-Δ reduced voltage starting (B)**

kW	HP																					
	1.5	2.2	3	4	5.5	7.5	9	11	15	18.5	22	30	37	45	55	75	90	110	150	200	260	
Motor rating	A																					
	Motor full load current																					
220V	A																					
	MCM magnetic contactor																					
3φ	A																					
	Thermal overload relay																					
50 / 60 Hz	A																					
	Rated current of heating element																					
30-SN	A																					
	MCS magnetic contactor																					
30-SN	A																					
	Fused (VDE0660 gT, delay type)																					
30-SN	A																					
	Circuit breaker																					
30-SN	A																					
	Rated current																					
30-SN	A																					
	Motor full load current																					
380V	A																					
	MCM magnetic contactor																					
3φ	A																					
	Thermal overload relay																					
50 / 60 Hz	A																					
	Rated current of heating element																					
30-SN	A																					
	MCS magnetic contactor																					
30-SN	A																					
	Fused (VDE0660 gT, delay type)																					
30-SN	A																					
	Circuit breaker																					
30-SN	A																					
	Rated current																					
30-SN	A																					
	Motor full load current																					

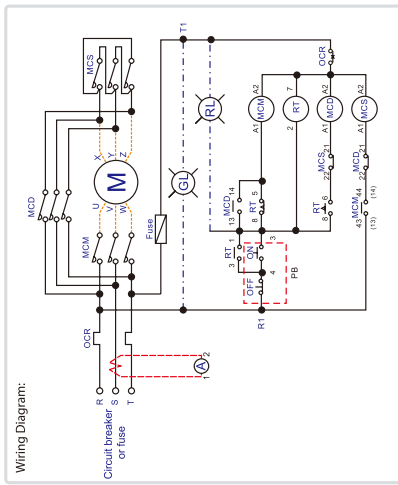



Giá bán đã bao gồm thuế VAT 10%

MS / STARTER

Khởi động từ - Contactor

Mã hàng	3φ 380V AC3			Tiếp điểm	Chọn rơ le nhiệt	Đơn giá (VND)
	KW	HP	A			
S-P 06	3	4	6	1a	TH-P09PP	230,000
S-P 09	4	5.5	9			240,000
S-P 11	5.5	7.5	12			286,000
S-P 12						314,000
S-P 16	7.5	10	18			410,000
S-P 21 A	11	15	21			426,000
S-P 30 T	15	20	30			572,000
S-P 35 T	18.5	25	35			613,000
S-P 40 T	22	30	40			1,004,000
S-P 50 T	30	40	52			1,225,000
S-P 60 T	37	50	65	1,318,000		
S-P 80 T	45	60	80	1,890,000		
S-P 100 T	60	80	105	2,117,000		
S-P 125 T	75	100	130	2,970,000		
S-P 150 T	90	125	160	3,920,000		
S-P 220 T	120	160	220	5,184,000		
S-P 300 T	160	220	300	8,000,000		
S-P 400 T	220	300	400	10,400,000		
M-600 C	315	420	600	33,000,000		

Rơ le nhiệt (Có thanh đồng kết nối) - Overload

Mã hàng	Dãy điều chỉnh nhiệt (A)	Đơn giá (VND)
TH-P09PP	1.3(1~1.6) ; 2(1.6~2.4) ; 3.2(2.4~4) ; 5(4~6)A	285,000
TH-P12(E)	0.25(0.19~0.31) ; 0.4(0.3~0.5) ; 0.6(0.45~0.75)A 0.9(0.7~1.1) ; 1.2(0.9~1.5) ; 1.7(1.3~2.1)A 2.1(1.6~2.6) ; 3.3(2.5~4.1) ; 4.4(3.4~5.4)A 6.5(5~8) ; 9(7~11) ; 11(9~13) ; 15(12~18)A	202,000
TH-P20V(E)	9(7~11) ; 11(9~13) ; 15(12~18) ; 21(17~24)A	227,000
TH-P20TAV(E)	28(22~34) ; 33(28~38) ; 40A(32~48)A	248,000
TH-P60V(E)	33(28~38) ; 40(32~48) ; 54(43~65)A	346,000
TH-P60TAV(E)	67(54~80) ; 80(60~100)A	378,000
TH-P120(E)	40(32~48) ; 54(43~65) ; 67(54~80) ; 80(60~100)	870,000
TH-P120TAV(E)	80(60~100) ; 105(80~130)A 130(100~160) ; 160(120~200)A	1,045,000
TH-P220T(E)	200(150~250)A	2,300,000
TH-P400T(E)	260(200~320) ; 350(260~400)A	3,300,000

Khởi động từ hộp

Mã hàng	3P 220V		3P 380V		Rơ le Nhiệt	Đơn giá (VND)
	KW	HP	KW	HP		
MS-P 11 PB	0.2	1/4	0.4	1/2	1.2(0.9~1.5)A	651,000
	0.3	2/5	0.75	1	1.7(1.3~2.1)A	
	0.4	1/2	1.1	1.5	2.1(1.6~2.6)A	
	0.75	1	1.5	2	3.3(2.5~4.1)A	
	1.1	1.5	2.2	3	4.4(3.4~5.4)A	
	1.5	2	3	4	6.5(5~8)A	
	2.2	3	3.7	5.5	9(7~11)A	
	3	4	5.5	7.5	11(9~13)A	
MS-P 16 PB	3.7	5	7.5	10	15(12~18)A	774,000
MS-P 21 PB	5.5	7.5	12	15	21(17~24)A	861,000
MS-P 35 TPB	7.5	10	15	20	28(22~34)A	1,502,000
MS-P 40 TPB	11	15	22	30	40(32~48)A	1,523,000

Phụ kiện Khởi động từ

Coil: 24.48.110.220.380V	Đơn giá (VND)	Tiếp điểm phụ (S-P11~21A)	Đơn giá (VND)
Coil dùng cho S-P 11~21	125,000	AP-11S	70,000
Coil dùng cho S-P 30/35/40	160,000	APS-11S	77,000
Coil dùng cho S-P 50/60	190,000	AP-22S	135,000
Coil dùng cho S-P 80	370,000		
Coil dùng cho S-P 100	480,000		
Coil dùng cho S-P 125/150	830,000	Nút nhấn - Push Button	Đơn giá (VND)
Coil dùng cho S-P 220	900,000	PB-2	70,000
Coil dùng cho S-P 300/400	5,000,000	PB-3	132,000

Khóa liên động	Đơn giá (VND)
MPU-11 dùng cho S-2XP 11,35,40,50,60T	100,000
MPU-21 dùng cho S-2XP 12,16,21,25T	120,000
MPU-50 dùng cho S-2XP 80T	180,000
MPU-125 dùng cho S-2XP 125~220T	330,000

Capacitor Unit	Kvar/380V	Đơn giá (VND)	
AP-40-A	dùng cho S-P 11	12.5	374,000
	dùng cho S-P 16	16.7	
	dùng cho S-P 21A	20	
AP-40-B	dùng cho S-P 40T	25	418,000
	dùng cho S-P 50T	33.3	
	dùng cho S-P 60T	45	
	dùng cho S-P 80T	60	

Contactor Relay

Mã hàng	Tiếp điểm phụ	Đơn giá (VND)
SR-P40	4NO / 3NO 1NC / 2NO 2NC	330,000
SR-P50	5NO / 4NO 1NC / 3NO 2NC / 2NO 3NC	385,000
SR-P80	8NO / 7NO 1NC / 6NO 2NC / 5NO 3NC / 4NO 4NC	484,000

Khởi động từ kép

Chuyên dùng cho cửa cuốn (Chuyển động thuận, nghịch)	Đơn giá (VND)
RC-11C Coil : 220 or 380VAC	957,000

Manual Motor Starter = MCB + Overload (3P)

Mã hàng	Current In (A)	HP 3φ 380V	Đơn giá (VND)
MR-32S-0.16	0.1~0.16	1/30	528,000
MR-32S-0.25	0.16~0.25	1/19	
MR-32S-0.4	0.25~0.4	1/8	
MR-32S-0.63	0.4~0.63	1/4	
MR-32S-1	0.63~1	1/3	
MR-32S-1.6	1~1.6	1/2	
MR-32S-2.5	1.6~2.5	1	
MR-32S-4	2.5~4	2	
MR-32S-6.3	4~6.3	3	
MR-32S-10	6~10	4~5	
MR-32S-14	9~14	5~7.5	539,000
MR-32S-18	13~18	10	
MR-32S-23	17~23	15	
MR-32S-25	20~25	15(16)	
MR-32S-32	24~32	20	



## Capacitor Unit



Capacitor Unit	Magnetic Contactor	Maximum operating power(kvar)		
		220~240V	400~440V	660~690V
AP-40 A	S-P11	6.7	12.5	18
	S-P16	8.5	16.7	24
	S-P21	10	20	30
AP-40 B	S-P40T	15	25	36
	S-P50T	20	33.3	48
	S-P60T	25	45	58
	S-P80T	35	60	75

## Manual Motor Starter

Side AX (MR-AN)



Front AX (MR-AE)



SHT (MR-AS)



AL (MR-AM)  
(For Magnetic Trip)



MMS

UVT (MR-AU)



**MCB (CB Tép) Tiêu chuẩn IEC60898 Màu trắng (6kA)**

Mã hàng	Dòng định mức (A)	kA	Đơn giá (VND)
BHA 1P	6.10.16.20.25.32.40A	6	68,000
	50.63A		72,000
BHA 2P	6.10.16.20.25.32.40A		145,000
	50.63A		150,000
BHA 3P	6.10.16.20.25.32.40A		240,000
	50.63A		248,000
BHA 4P	6.10.16.20.25.32.40A		380,000
	50.63A		430,000

**CB Chống giật (RCBO) Tiêu chuẩn IEC60947 30mA 0.1s**

Mã hàng	Dòng định mức (A)	kA	Đơn giá (VND)
BHL 1P+N	6.10.16.20A	6	310,000
	25.32A		330,000
BHL 2P	6.10.16.20.25.32A		560,000
	40.50.63A		570,000
BHL 3P	6.10.16.20.25.32A		700,000
	40.50.63A		840,000
BHL 4P	6.10.16.20.25.32A		860,000
	40.50.63A		1,050,000

**MCB (CB Tép) Tiêu chuẩn IEC60898 Màu trắng (10kA)**

Mã hàng	Dòng định mức (A)	kA	Đơn giá (VND)
BHA 1P	6.10.16.20.25.32.40A	10	107,800
	50.63A		129,800
	80.100A		192,500
BHA 2P	6.10.16.20.25.32.40A		225,500
	50.63A		275,000
	80.100A		451,000
BHA 3P	6.10.16.20.25.32.40A		363,000
	50.63A		495,000
	80.100A		715,000
BHA 4P	6.10.16.20.25.32.40A		594,000
	50.63A		737,000
	80.100A		935,000

**CB Chống giật (RCBO) Tiêu chuẩn CNS 14816-2 30mA 0.1s**

Mã hàng	P	Dòng định mức (A)	kA	Đơn giá (VND)
NVB-50L	2P	15.20.30.40.50A	5	620,000
NVB-50UL	1P		10	508,000
NVB-50UL	2P		10	846,000

**CB Chống giật (RCCB) Tiêu chuẩn CNS 14816-2 30mA 0.1s**

Mã hàng	P	Dòng định mức (A)	kA	Đơn giá (VND)
BL-KF	2P	15.20.30A	1.5	369,000
BL-K30F	3P		1.5	527,000
NV-BF	2P		1.5	280,000

**Biến tần dòng SS2 điện áp AC 220V – 240V**

Mã hàng	KW	KVA	HP	Input	Đơn giá (VND)
SS(2) Series ~ Tải đơn giản					
SS(2)-021-0.75KD	0.75	1.5	1	1Ø 220V	5,520,000
SS(2)-021-1.5KD	1.5	2.5	2		6,440,000
SS(2)-021-2.2KD	2.2	4.2	3		6,555,000
SS(2)-023-3.7KD	3.7	7	5	3Ø 220V	10,465,000

**Biến tần dòng SE2 điện áp AC 380V – 480V**

Mã hàng	KW	KVA	HP	Input	Đơn giá (VND)
SE 2 Series ~ Tải trung bình					
SE(2)-023-5.5KDL	5.5	9.2	7.5	3Ø 220V	17,020,000
SE(2)-023-7.5KDL	7.5	12.6	10		21,505,000
SH Series ~ Tải nặng					
SH-020-11KBC	11	17.6	15	3Ø 220V	25,300,000
SH-020-15KBC	15	23.3	20		32,200,000

**Biến tần dòng SS2 điện áp AC 380V – 480V**

Mã hàng	KW	KVA	HP	Input	Đơn giá (VND)
SS Series ~ Tải đơn giản					
SS(2)-043-0.75KD	0.75	2	1	3Ø 380V	6,555,000
SS(2)-043-1.5KD	1.5	3	2		7,590,000
SS(2)-043-2.2KD	2.2	4.6	3		8,395,000
SS(2)-043-3.7KD	3.7	6.9	5		10,120,000
SS(2)-043-5.5KD	5.5	10	7.5		14,145,000
SE 2 Series ~ Tải trung bình					
SE2-043-0.4KDL	0.4	1.2	0.5	3Ø 380V	7,590,000
SE2-043-0.75KDL	0.75	2	1		7,820,000
SE2-043-1.5KDL	1.5	3	2		8,510,000
SE2-043-2.2KDL	2.2	4.6	3		9,315,000
SE2-043-3.7KDL	3.7	6.9	5		11,845,000
SE2-043-5.5KDL	5.5	9.1	7.5		16,905,000
SE2-043-7.5KDL	7.5	13	10		19,435,000
SE2-043-11KDL	11	18	15		25,875,000

**Biến tần dòng SF điện áp AC 380V – 480V**

Mã hàng	KW	KVA	HP	Input	Đơn giá (VND)
SF Series ~ Tải Bơm & Quạt					
SF-040-5.5kA	5.5	10	7.5	3Ø 380V	14,950,000
SF-040-7.5kA	7.5	14	10		18,285,000
SF-040-11kA	11	18	15		21,045,000
SF-040-15kA	15	25	20		24,495,000
SF-040-18.5kA	18.5	29	29		30,360,000
SF-040-22kA	22	34	30		43,010,000
SF-040-30kA	30	46	40		48,645,000
SF-040-37kA	37	56	50		63,250,000
SF-040-45kA	45	69	60		69,000,000
SF-040-55kA	55	84	75		80,500,000
SF-040-75kA	75	114	100		113,390,000
SF-040-90kA	90	137	120		149,960,000
SF-040-110kA	110	168	150		186,070,000
SF-040-132kA	132	196	175		230,000,000





## Closing coil unit



Closing Coil	
CMD01	AC 380V
CMD02	AC 220V
CMD03	DC 220V
CMD04	DC 110V
CMD05	AC 110V

## Shunt release unit



Shunt Trip	
SHT01	AC 380V
SHT02	AC 220V
SHT03	DC 220V
SHT04	DC 110V
SHT05	AC 110V

## Under voltage trip unit



Under Voltage Trip	
UVT01	Instantaneous AC 380V
UVT02	Delay AC 380V
UVT03	Instantaneous AC 220V
UVT04	Delay AC 220V
UVT05	Instantaneous AC 110V
UVT06	Delay AC 110V

## Locking device



Locks	
LOK01	3 Locks, 2 Keys
LOK02	Door Interlock
LOK03	Button Lock
LOK04	Racking Lock
LOK05	Key Lock
LOK06	Lock Device
LOK07	2 Locks, 1 Key

## Mechanical interlock device



Mechanical Interlock	
MIL01	Drawout, Vertical, For 2
MIL02	Drawout, Horizontal, For 2, W/O cable
MIL03	Fixed, Vertical, For 2
MIL04	Fixed, Horizontal, For 2, W/O cable
MIL05	Drawout, Vertical, For 3
MIL06	Fixed, Vertical, For 3
MIL07	Drawout, Horizontal, Ø2.5mm*1.5m
MIL08	Fixed, Horizontal, Ø2.5mm*1.5m
MIL09	Drawout, Horizontal, For 3

## Giá bán đã bao gồm thuế VAT 10%

## ACB / SPD

### ACB 3P FIXED Bao gồm: MD, CC, SHT, AX5C (Ics= 100% Icu)

Mã hàng	Dòng định mức (A)	kA	Đơn giá (VND)
BW 2000-HN 3P	630A	85	46,000,000
	800A		46,000,000
	1000A		48,000,000
	1250A		49,000,000
	1600A		54,000,000
BW 3200-HN 3P	2000A	100	61,000,000
	2500A		67,500,000
	3200A		81,000,000

### ACB 4P FIXED Bao gồm: MD, CC, SHT, AX5C (Ics= 100% Icu)

Mã hàng	Dòng định mức (A)	kA	Đơn giá (VND)
BW 2000-HN 4P	630A	85	51,000,000
	800A		51,000,000
	1000A		53,000,000
	1250A		54,000,000
	1600A		60,000,000
BW 3200-HN 4P	2000A	100	64,000,000
	2500A		74,000,000
	3200A		89,000,000

### ACB 3P DRAW OUT Bao gồm: MD, CC, SHT, AX5C (Ics= 100% Icu)

Mã hàng	Dòng định mức (A)	kA	Đơn giá (VND)
BW 2000-HN 3P	630A	85	55,000,000
	800A		55,000,000
	1000A		56,000,000
	1250A		58,000,000
	1600A		63,000,000
BW 3200-HN 3P	2000A	100	69,000,000
	2500A		81,000,000
BW 4000-HN 3P	3200A	100	97,000,000
	4000A		199,000,000
BW 6300-H 3P	5000A	130	235,000,000
	6300A		260,000,000

### ACB 4P DRAW OUT Bao gồm: MD, CC, SHT, AX5C (Ics= 100% Icu)

Mã hàng	Dòng định mức (A)	kA	Đơn giá (VND)
BW 2000-HN 4P	630A	85	60,000,000
	800A		60,000,000
	1000A		62,000,000
	1250A		64,000,000
	1600A		71,000,000
BW 3200-HN 4P	2000A	100	76,000,000
	2500A		89,000,000
BW 4000-HN 4P	3200A	100	107,000,000
	4000A		210,000,000
BW 6300-H 4P	5000A	130	300,000,000

### Phụ kiện ACB

Mã hàng	Đơn giá (VND)
UVT Bộ bảo vệ thấp áp delay 5 sec	9,350,000
Khóa liên động 2-way (Dùng cho 2 ACB)	21,450,000
Khóa liên động 3-way (Dùng cho 3 ACB)	33,000,000
Bảng điều khiển dùng cho ATS	9,900,000

### ATS Loại MCCB Tiêu chuẩn IEC60947-2 – Giá đã bao gồm bảng điều khiển

Mã hàng	Dòng định mức (A)	kA	Đơn giá (VND)
BS100SN 3P	100A	15	13,762,000
BS100HN 3P		30	17,026,000
BS250SN 3P	250A	30	19,587,000
BS400SN 3P	250.300.350.400A	35	33,925,000
BS400HN 3P		50	34,053,000
BS630SN 3P	500.600.630A	35	50,887,000
BS630HN 3P		50	59,208,000
BS800SN 3P	700.800A	50	64,713,000
BS1000HS 3P	1000A	100	145,620,000
BS1200HS 3P	1200A	100	165,463,000
BS1600HS 3P	1400.1600A	100	198,108,000

### Chống sét lan truyền

Mã hàng	I <sub>max</sub> (kA)	kA	Đơn giá (VND)					
			1P	2P(1P+N)	3P(2P+N)	4P(3P+N)	1P+PE	3P+PE
BHP-20	20	8/20	1,320,000	2,760,000	4,000,000	5,400,000	3,350,000	6,000,000
BHP-40	40		1,960,000	3,960,000	5,880,000	7,900,000	4,600,000	8,530,000
BHP-80	80		2,310,000	4,620,000	6,840,000	9,200,000	5,250,000	9,850,000
BHP-100	100		6,200,000	12,800,000	19,000,000	25,500,000	13,400,000	26,000,000
BHP-250	250	10/350	8,700,000	14,300,000	21,900,000	27,200,000	16,100,000	29,100,000
Counter-Bộ đếm TAD-04-99			3,600,000					

### Đồng hồ đa năng: IEC 62052-22 RS-485

Mã hàng	Đơn giá (VND)
SPM-3	7,700,000
SPM-8	12,500,000

### Relay bảo vệ pha- mất pha

Mã hàng	Đơn giá (VND)
SLPR-4S (3P 220~440V)	1,100,000

### Bộ điều khiển tụ bù

Mã hàng	Đơn giá (VND)
SH-JKWA-12J (APFR-12 Cấp)	9,000,000





CIRCUIT BREAKER ( MCCB / ELCB / EMCCB / MCB )

## Breaker & Switchgear System



AIR CIRCUIT BREAKER

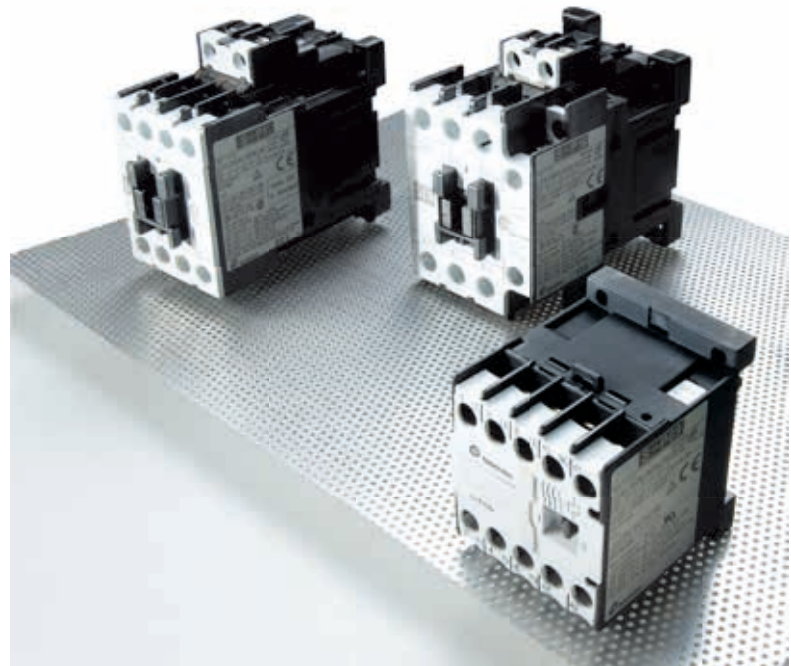

MAGNETIC CONTACTOR / SWITCH ( CONTACTOR / MS / MMS )



AUTOMATIC TRANSFER SWITCHES



SURGE PROTECTIVE DEVICE



SMART METER



INVERTER



LOW VOLTAGE POWER CAPACITORS

### Headquarters

16F, No.88, Sec. 6, Zhongshan N. Rd., Shilin Dist.,  
Taipei City 11155, Taiwan  
T. +886-2-2834-2662  
F. +886-2-2836-6187  
<http://www.seec.com.tw>

### Breaker & switchgears overseas sales dept.

3F, No.9, Sec. 1, Chang-an E. Rd., Zhongshan Dist.,  
Taipei City 10441, Taiwan  
T. +886-2-2541-9822  
F. +886-2-2581-2665  
e-mail. [b.export@seec.com.tw](mailto:b.export@seec.com.tw)  
<http://circuit-breaker.seec.com.tw>

Distributor